



**TITLE: Vaccine freezer or combined vaccine and water-pack freezer: Solar-direct drive**

<i>Product verification protocol:</i>	E003/FZ04-VP.1
<i>Applies to specification ref(s):</i>	E003/FZ04.1
<i>Issue date:</i>	28 November 2022
<i>Date of previous revision:</i>	New protocol

**Contents**

**1. Scope.....2**

**2. Normative references .....2**

**3. Terms and definitions.....3**

**4. Applicability.....5**

**5. Type-testing procedure .....5**

5.1 Evidence of conformity assessment .....5

5.2 Number of samples.....5

5.3 Test procedure .....5

5.3.1 *Test 1: Type examination*.....5

5.3.2 *Test temperatures and simulated solar power supply* .....7

5.3.3 *Test 2: Cool-down, stable running and power consumption*.....8

5.3.4 *Test 3: Autonomy (vaccine compartment) and power consumption:* .....10

5.3.6 *Test 5: Day/night and power consumption*.....12

5.3.7 *Test 6: Autonomy time (water pack compartment, combined appliances only)*.....14

5.3.8 *Test 7: Door opening* .....14

5.4 Test criteria for qualification .....15

**6. Quality control checklist .....16**

5.5 Quality control standards .....16

5.6 On-site inspection.....16

**7. Prequalification evaluation.....16**

**8. Modified products .....16**

**Annex 1 – General test conditions .....17**

**Annex 2 – Temperature sensor specification and locations .....19**

**Revision history .....23**

## 1. Scope

To assess whether an appliance meets PQS equipment specification **WHO/PQS/E003/FZ04.1** Vaccine freezer or combined vaccine and water-pack freezer: Solar Direct Drive, it shall be tested to verification protocol **WHO/PQS/E003/FZ04 - VP.1** detailed here.

These appliances are not suitable for simultaneous frozen vaccine storage and [water pack](#) freezing if a single freezer compartment is provided. Optionally, a two-compartment freezer may be provided where one compartment is dedicated for frozen vaccine storage and the second compartment is dedicated to [water pack](#) freezing.

Prequalification testing will establish a minimum [solar radiation reference period](#) below which the product should not be used. Testing will also establish the maximum [autonomy](#) that the vaccine storage freezer can achieve. Three temperature zone designations are described: [moderate zone](#), [temperate zone](#) and [hot zone](#). All appliances must fully meet the stated performance requirements for [hot zone](#) (+43°C) test temperatures.

PQS specification **WHO/PQS/E003/PV01** specifies a compatible Type 2 solar power system to directly power the appliance.

Appliance design must account for performance degradation over the 10-year target life of the appliance in order to sustain [acceptable temperature range](#) for frozen vaccine storage and other appliance features (if included).

## 2. Normative references

Use most recent version.

EMAS: European Union Eco-Management and Audit Scheme.

EN ISO 6270-1 / ASTM D2247 / EN 13523-26: 2017 Determination of resistance to humidity – Part 1: Continuous condensation.

EN ISO 6270-2 / EN 13523-25: 2017 Determination of resistance to humidity - Part 2: Procedure for exposing test specimens in condensation-water atmospheres.

Generic Guide for the Field Evaluation of New Technologies for WHO PQS Pre-qualification.

GHS Rev 5. United Nations: Globally Harmonized System of Classification and Labelling of Chemicals.

IEC 60335-1: 2020 Household and similar electrical appliances - Safety

□ Part 1: General requirements.

IEC 60335-2-24: 2020: Household and similar electrical appliances - Safety - Part 2-24: Particular requirements for refrigerating appliances, ice-cream appliances and icemakers.

IEC 60364-1: 2005: Low -voltage electrical installations - Part 1: Fundamental principles, assessment of general characteristics, definitions.

IEC 61000-6-1: 2016 Electromagnetic compatibility (EMC) Generic standards - Immunity for residential, commercial and light-industrial environments.

IEC 61000-6-3: 2020 Electromagnetic compatibility (EMC) Generic standards - Emission standard for equipment in residential environments<sup>1</sup>.

IEC 62552-1:2015+AMD1: 2020 CSV Consolidated version Household refrigerating appliances - Characteristics and test methods - Part 1: General requirements.

Intergovernmental Panel on Climate Change: most recent assessment

ISO 2409: 2020 Paints and varnishes – crosscut test (external cabinet).

ISO 6272 / EN 13523-5: 2014 Impact resistance - external cabinet.

ISO 9001: 2015 Quality Management Systems – Requirements.

ISO 14001: 2015 Environmental management systems - Requirements with guidance for use.

ISO 20282-1: 2006 Ease of operation of everyday products - Part 1: Context of use and user characteristics.

ISO/IEC 17025: 2017 General requirements for the competence of testing and calibration laboratories.

WHO/PQS/E003/BC01: Performance specification: Global asset identification.

WHO/PQS/E003/FZ04: Performance specification: Vaccine freezer or combined vaccine freezer and water-pack freezer: Solar direct drive.

WHO/PQS/E003/PV01: Performance specification: Solar power system for compression-cycle vaccine refrigerator or combined refrigerator and water-pack freezer.

WHO/PQS/E003/PV01-VP.1: Type-examination protocol: Solar power system for compression-cycle vaccine refrigerator or combined refrigerator and water-pack freezer.

WHO/PQS/E003/PV01-VP.2: Quality assurance protocol: Solar power system for compression-cycle vaccine refrigerator or combined refrigerator and water-pack freezer.

WHO/PQS/E005/IP01: Performance specification: Water-packs for use as ice-packs, cool-packs and warm-packs.

WHO/PQS/E006/TH06: Performance specification: Integrated electronic maximum-minimum thermometer, with factory programmed alarms, for vaccine refrigerators and freezers.

### 3. Terms and definitions

Acceptable temperature range: The acceptable temperature range for storing frozen vaccine is -15°C to -25°C.

Autonomy (water pack compartment): For combined vaccine storage freezer with separate water pack freezer compartment the time in hours that a solar direct drive water-pack freezer can maintain the minimum capacity of fully frozen water-packs under low solar radiation conditions (e.g. rain). Autonomy is measured as described in **WHO/PQS/E003/FZ04-VP.1** Test 6.

---

<sup>1</sup> Note from the IEC: The intention is that all equipment used in the residential, commercial and light-industrial environments are covered by IEC 61000-6-3 or IEC 61000-6-8.

**Autonomy (vaccine compartment):** Time in hours during which all points in the vaccine compartment remain within the acceptable temperature range. Autonomy is measured as described in **WHO/PQS/E003/FZ04-VP.1** Test 3.

**Cool-down time:** The time required to initially cool an appliance to achieve stable operating conditions within the acceptable temperature range for frozen vaccine storage and achieve its full autonomy time.

**Freezer temperature:** the warmest internal temperature that the freezer actually achieves in use. The freezer should not be warmer than this temperature +1°C. If more than one freezer temperature is possible by means of varying the control setting(s), the setting tested according to this verification protocol is the freezer temperature that will be prequalified.

**Gross volume:** The measured volume of the air space inside the internal compartment(s) with the door or lid shut.

**Hot zone:** Hot zone appliances must operate at a steady +43°C ambient temperature and over a +43°C/+25°C Day/night cycling temperature range.

**In writing:** Communication by letter, fax or email.

**Installation:** The appliance specified in this document, connected to a solar power system complying with specification **WHO/PQS/E003/PV01**.

**Legal manufacturer:** The natural or legal person with responsibility for the design, manufacture, packaging and labelling of an appliance or device before it is placed on the market under the person's own name, regardless of whether these operations are carried out by that person or on their behalf by a third party.

**Moderate zone:** Moderate zone appliances must operate at a steady +27°C ambient temperature and over a +27°C/+10°C day/night cycling temperature range.

**Montreal Protocol:** Montreal Protocol on Substances that Deplete the Ozone Layer and Kigali Amendment 2016.

**Phase change material (PCM):** A material, other than water, which changes state between solid and liquid or changes between two different solid crystallization states over a defined temperature range, absorbing or releasing heat during the phase change. This process is reversible and can be useful for thermal control in cold chain devices and products.

**Net storage capacity:** This is the gross volume multiplied by a utilization rate of 0.67.

**Reseller:** A commercial entity, licensed to act on behalf of a legal manufacturer, and which carries appliance liability and warranty responsibilities no less onerous than those carried by the legal manufacturer.

**Solar radiation reference period:** The minimum average daily solar radiation on the plane of the solar array that is required to properly power the solar-powered appliance, expressed in kWh/m<sup>2</sup>/day.

**Temperate zone:** Temperate zone appliances must operate at a steady +32°C ambient temperature and over a +32°C/+15°C Day/night cycling temperature range.

**Vaccine storage capacity:** The net storage capacity is the space where it is suitable (both thermally and ergonomically) to store vaccines with any components necessary to operate within the acceptable temperature range fully prepared and in place. If a legal manufacturer would declare more than one vaccine storage capacity for the same internal and external dimensions, they must prequalify with different branding, one model for each different storage volume. This capacity will be published as vaccine volume in litres.

Water-pack: A flat, leak proof, plastic container, filled with tap water, complying generally with specification **WHO/PQS/E005/IP01**.

Water-pack freezing capacity: The daily maximum weight and number of water-packs which can be fully frozen, in one batch, during a 24-hour freezing cycle when no vaccine is stored in the water-pack freezing compartment. During this period the temperature of the vaccine storage compartment must remain within the acceptable temperature range.

#### 4. Applicability

Type-testing will be carried out by an independent **ISO/IEC 17025** testing laboratory, accredited by WHO.

#### 5. Type-testing procedure

##### 5.1 Evidence of conformity assessment

Products must carry the CE mark, or UL mark and/or equivalent internationally accepted evidence of conformity assessment.

##### 5.2 Number of samples

The [legal manufacturer](#) or [reseller](#) must supply the testing laboratory with a full duplicate set of the Product Dossier already supplied to WHO in accordance with the requirements of specification clause 7. One sample of the product is required. If more than one version of the product is available (for example, for different climate zones), provide one sample of each version.

##### 5.3 Test procedure

###### 5.3.1 *Test 1: Type examination*

- **Step 1:** Unpack the product. Using the manufacturer's installation instructions only, set up the system components. Record the process and any problems encountered.
- **Step 2:** Record any defects, damage or any problem which could make it difficult or impossible to test the appliance.
- **Step 3:** Record any differences between the samples ordered and those received.
- **Step 4:** Tabulate the following information for each model submitted for examination. Obtain any additional supporting information required [in writing](#) from the [legal manufacturer](#) or [reseller](#) and attach this information to the report:

###### *Identification:*

- Code (a unique identifier to be assigned by the testing laboratory).
- Model.
- [Legal manufacturer](#) or [reseller](#).

- Product type (i.e. vaccine freezer or combination unit).
- Country of origin.
- Conformity assessment markings (e.g., list as UL mark, CE mark and/or equivalent internationally accepted evidence of conformity assessment).

*Performance characteristics:* Mark if appliance conforms/does not conform to each specification clause. If a specification clause has more than one requirement and does not conform note the reason for not conforming. Report in the following order:

- 4.2.1 *Operating temperature range*
- 4.2.2 *Refrigeration cycle*
- 4.2.3 *Voltage*
- 4.2.4 *Vaccine storage capacity*
- 4.2.5 *Water-pack freezing and storage compartment capacity (optional)*
- 4.2.6 *Simultaneous vaccine storage and water-pack freezing warning*
- 4.2.7 *Temperature control*
- 4.2.8 *Thermostat*
- 4.2.9 *Thermometer*
- 4.2.10 *Indicator light*
- 4.2.11 *Autonomy*
- 4.2.12 *Power system requirements*
- 4.2.13 *Evaporator configuration*
- 4.2.14 *Lock*
- 4.2.15 *Corrosion resistance*
- 4.2.16 *Electrical safety rating*
- 4.2.17 *Markings*
- 4.2.18 *Labelling*
- 4.2.19 *Electromagnetic compatibility*
- 4.2.20 *Equipment monitoring system*
- 4.3.1 *Ambient temperature range during transport and storage*
- 4.3.2 *Ambient humidity range during transport, storage and use*
- 4.4.1 *Overall dimensions*
- 4.4.2 *Weight*
- 4.4.3 *Spacers*
- 4.5.1 *Electrical components*
- 4.5.2 *Power switch*
- 4.6.1 *General design*
- 4.6.2 *Control panel, indicator light and thermometer*
- 4.7.1 *Refrigerant*
- 4.7.2 *Thermal insulation foaming agents*
- 4.7.3 *Other restricted materials*
- 4.7.4 *PCM*
- 4.8 *Warranty*
- 4.9.1 *Essential spare parts and user maintenance tools/supplies*
- 4.10 *Disposal and recycling*
- 4.11 *Instructions*

- **Step 5:** Take a front view photograph of the appliance with the door open. Take additional photographs showing all external surfaces including top, sides and rear of the appliance, the interior layout, the [vaccine storage compartment including baskets and shelves](#), the compressor or cooling system and a close-up of the thermometer, indicator light(s), the control(s), control panel and any special features or identified weaknesses of the appliance. High resolution digital images should be provided in the report to WHO PQS.

**Acceptance criteria:** Inspection indicates full conformity with all specification requirements.

### 5.3.2 *Test temperatures and simulated solar power supply*

The specific tests listed below can apply equally to [moderate zone](#), [temperate zone](#) and [hot zone](#). Appropriate test chamber temperatures are as follows: M:<27°C> for [moderate zone](#); T:<32°C> for [temperate zone](#); T:<43°C> for [hot zone](#).

Temperature results to be presented graphically where t = 0 hours from the start of each test. Power consumption or compressor on-off cycling should be displayed with each temperature graph.

For testing purposes, a means of simulating the solar day must be arranged to take into account the varying amount of solar radiation from dawn to midday to dusk with a 12-hour night. The minimum [solar radiation reference period](#) for all appliances is 3.5kWh/m<sup>2</sup>/day designed to represent the average daily solar radiation received over a 24-hour period. All appliances must be tested at the minimum solar radiation reference period of 3.5 kWh/m<sup>2</sup>/day or less.

[Legal manufacturer](#) to supply solar power system electrical requirements (per **WHO/PQS/ E003/PV01** solar power system specifications). A solar power simulator is required to provide power to the appliance. All performance tests use a direct current source to simulate a solar power array. To simulate a solar power array, use an electronic power supply or multiple power supplies connected to timers. The combined power supply and timer accuracy must be of  $\pm 0.1\%$  or better.

The power supply must simulate a [solar radiation reference period](#) of 3.5 kWh/m<sup>2</sup>/day by staging the power output with output stages equal to:

- 1 hour at 50 W/m<sup>2</sup>
- 2.5 hours at 250 W/m<sup>2</sup>
- 0.5 hours at 350 W/m<sup>2</sup>
- 4 hours at 450 W/m<sup>2</sup>
- 0.5 hours at 350 W/m<sup>2</sup>

2.5 hours at 250 W/m<sup>2</sup>  
1 hour at 50 W/m<sup>2</sup>  
12 hours at 0 W/m<sup>2</sup>

The [legal manufacturer](#) must also specify the required solar power profile including:

- Volts.
- Amperes (Imp from solar module specification).
- The daily run time in hours.
- Cool down time (as instructed in User / Technician manuals).

Amperage will be verified from solar module data sheets as published by the solar module manufacturer and will be based on solar module Imp specifications as reported under standard test conditions (STC =1000 W/m<sup>2</sup> at 25°C). The current will vary directly with the power supply output variables (e.g. use 45% of reported STC value for output stage 0.45 kW/m<sup>2</sup>). The voltage may remain constant or may vary only if cooling system voltage varies with corresponding amperage.

The simulated solar power supply must be set up, as described above, to model a typical solar radiation pattern experienced over an average day at the minimum [solar radiation reference period](#). Note that in actual field conditions the power supply will be a solar array with similar power output to the manufacturers specified power supply. The power supply and runtime will be based on the [solar radiation reference period](#) the manufacturer specifies and this will be reported as the minimum solar resource for which the product is prequalified.

Starting with Test 2 all tests must be carried out in the order as stated in this protocol. There may be a time restriction between the end of a previous test and the beginning of the next test. In some cases, the next test follows immediately.

### 5.3.3 *Test 2: Cool-down, stable running and power consumption*

**Application:** all appliances.

**Power:** Simulated solar power as clause 5.3.2.

- **Step 1:** Install the appliance and temperature sensors in accordance with **Annex 1**. Set the test chamber ambient temperature to +43°C in accordance with **Annex 1** and leave the lid or door open with the appliance empty with the power supply switched off. All temperature sensors, ambient and internal, must be at the +43°C ± 1°C for at least 48 hours in accordance with **Annex 1** before commencing Step 2.
- **Step 2:** Close the lid or door of the freezer, adjust the water pack compartment thermostat per manufacturer instructions (combined appliances only), switch on the appliance and leave it to initially stabilize. Initial stabilization is accomplished when the appliance demonstrates all of the following:
  - the thermal storage has been cooled for a time period no less than the



cool down time period stated in the instructions provided by the manufacturer (e.g. if user/technician instruction manuals state cool down time is 7 days then at least a 7-day cool down test period is required);

- the internal temperatures in the vaccine storage compartment are within the [acceptable temperature range](#); and
  - the cooling system has exhibited consistent on/off operation for two consecutive days of this test (e.g. the same number of on/off cycles per day).
- **Step 3:** Record temperatures every minute from pre-stabilization until the end of the test. Record the energy consumption and determine the compressor duty cycle. Measure electricity consumption over the initial 24-hour stabilization period in kWh/day and calculate the percentage on-time<sup>2</sup> over this period. Report the solar power system voltage and amperage, solar profile (see clause 5.3.2) and total hours to cool down.
  - **Step 4:** With temperature stabilization achieved, record temperatures every minute for at least one additional complete solar cycle. Measure electricity consumption and the cooling system duty cycle over the same test duration and report energy consumption in kWh/day, the percentage on-time over the 12 hour solar phase and graphically display on/off cycles. Report the solar power profile (see clause 5.3.2).

**Acceptance criterion (cool down):** Stabilized internal temperatures maintained in the vaccine storage compartment at or below the [freezer temperature](#) and within the [acceptable temperature range](#) and stabilized internal temperatures maintained below 0°C in the water-pack freezing compartment (if present) achieved within the test period. Water-pack freezing compartment excursions above 0°C are permitted during the night phase and first three hours of the 12-hour solar phase of the simulated solar power cycle. No standard set for the cool-down time but the period will be reported.

Note: Time to cool down in hours to be compared with the manufacturer's declared [cool-down time](#) (declared cool down time as published instructions). If cool down time is greater than printed instructions in user/technician manuals, then the manufacturer will be required to revise and publish instructions that cool down time is equal or exceed test result.

**Rejection criterion (cool down):** Failure to stabilize at or below the [freezer temperature](#) and within the [acceptable temperature range](#).

**Acceptance criteria (stable running):** Stabilized internal temperatures maintained within acceptable temperature range in the vaccine compartment and

---

<sup>2</sup> Measure the duty cycle by timing from the end of one cycle to the end of a corresponding cycle approximately 24 hours later.

below 0°C in the water-pack freezing compartment (in combined appliances). No standard set for power consumption but report the energy consumption in kWh/day, the percentage on-time during the 12-hour solar phase and graphically display on/off cycles.

**Rejection criterion (stable running):** Failure to meet one or more of the acceptance criteria.

#### 5.3.4 *Test 3: Autonomy (vaccine compartment) and power consumption:*

**Application:** all appliances.

**Power:** Simulated solar power as clause 5.3.2.

- **Step 1:** For appliances without water pack freezing compartment continue the Test 2 conditions with the vaccine storage compartment stabilized between -15°C and -25°C. For combined appliances continue the Test 2 conditions with the water-pack freezing compartment empty and the vaccine storage compartment stabilized between -15°C and -25°C.
- **Step 2:** Connect appliance to a reduced output power supply at the time when the compressor or cooling circuit is turned off at the end of the 12-hour solar cycle. The reduced output power supply must provide the same voltage and daily runtime as specified by the manufacturer, but no more than 5% of the solar array ampere (Imp) input specified by the manufacturer based on the [solar radiation reference period](#). Measure electricity consumption and the cooling system duty cycle over the same test duration and report energy consumption in kWh/day, the percentage on-time over the 12-hour solar phase and graphically display on/off cycles.
- **Step 3:** Monitor the temperature of the vaccine load at one-minute intervals. Discontinue Step 3 testing at the moment when the warmest point in the load systematically exceeds -15°C and record the elapsed time since switched off and report as the vaccine compartment freezer autonomy. Record the position of the warmest point and report autonomy in hours.

**Acceptance criterion:** Vaccine storage freezer autonomy minimum 72 hours at the minimum [solar radiation reference period](#) and when tested for the [hot zone](#).

**Rejection criterion:** Failure to meet the minimum [autonomy](#) periods during [hot zone](#) testing.

#### 5.3.5 *Test 4: Water-pack freezing capacity, water-pack storage compartment capacity and power consumption:*

**Application:** Combined appliances only.

**Power:** Simulated solar power as clause 5.3.2.

- **Step 1:** Continue the Test 3 conditions. DO NOT adjust the water pack freezer thermostat.

- **Step 2:** Label and stabilize water-packs at +43°C.
- **Step 3:** At the end of the 12-hour night-time phase of a 24-hour cycle load a minimum of 1.6 kg of water-packs and not less than 2.4 kg of water-packs per 50 litres of gross freezer volume into the freezer compartment in accordance with user instructions which includes use of any rack or structure provided for holding water-packs. The process<sup>3</sup> to achieve the maximum freezing capacity must be stated in the user instructions.
- **Step 4:** Record water pack freezer and vaccine compartment temperatures every minute for the following 24 hours. Measure electricity consumption and the cooling system duty cycle over the same duration. Report energy consumption in kWh/day, percentage on-time over the 12-hour solar phase and graphically display on/off cycles.
- **Step 5:** At the end of the next 12-hour night phase remove all water-packs and determine which are fully frozen and which are not fully frozen per instructions in **Annex 1** – Fully frozen water-pack determination. Record each water-pack volume, location and condition (i.e. fully frozen or not fully frozen). Do not return frozen packs to the freezer at this time. Note: It must be possible to remove frozen water-packs without any undue force or delay. Defrosting the freezer to enable removal is not acceptable.
- **Step 6:** Repeat steps 3 to 5 loading more stabilized water-packs in accordance with user instructions up to the point when either:
  - the total net weight of fully frozen water-packs has not increased since the previous cycle; or
  - until the freezing compartment is full; or
  - the temperature of the vaccine load exceeds -15°C on one or more sensors.
 The number and volume of fully frozen water-packs at the end of Step 6 are to be reported. This is the appliance's daily water-pack freezing capacity.
- **Step 7:** At the end of the 12-hour night-time phase of a 24-hour cycle load water-packs equal to the minimum daily water-pack freezing capacity determined in Step 6 into the freezer compartment in accordance with user instructions which includes any rack or structure provided for holding water-packs. The process to achieve the maximum freezing capacity must be stated in the user instructions.
- **Step 8:** Record water pack and vaccine compartment temperatures every minute for the following 24 hours. Measure electricity consumption and the cooling system duty cycle over the same duration. Report energy consumption in kWh/day, percentage on-time over the 12-hour solar phase and graphically display on/off cycles.
- **Step 9:** At the end of the next 12-hour night phase remove all water-packs and quickly determine which are fully frozen and which are not fully frozen per instructions in **Annex 1** – Fully frozen water-pack determination. Record each water-pack volume, location and condition (i.e. fully frozen or not fully frozen). Replace all packs immediately and add more stabilized water-packs in

---

<sup>3</sup> Manufacturer should state the number of water-packs to be loaded to give the maximum daily water-pack freezing capacity and the number of water-packs to be loaded on Day 1, Day 2, Day 3 etc. to give the maximum water-pack storage compartment capacity.

accordance with user instructions. Note: It must be possible to remove frozen water-packs without any undue force or delay. Defrosting the freezer to enable removal is not acceptable.

- **Step 10:** Repeat Steps 7 to 9 up to the point when either:
  - the total net weight of fully frozen water-packs has not increased since the previous cycle; or
  - until the freezing compartment is full; or
  - the temperature of the vaccine load exceeds  $-15^{\circ}\text{C}$  on one or more sensors.The number and volume of fully frozen water-packs at the end of Step 10 are to be reported. This is the appliance's water-pack storage compartment capacity.

**Acceptance criteria:** (water-pack freezing capacity): Stabilized internal temperatures maintained between  $-25^{\circ}\text{C}$  and  $-15^{\circ}\text{C}$  in the vaccine storage compartment. For freezers of less than 50 litres of gross freezer volume a minimum of 1.6 kg of fully frozen water-packs must remain fully frozen at the end of the 12-hour night phase whilst maintaining the temperature control specified in clause 4.2.7. For freezers with at least 50 litres of gross freezer volume a minimum of 2.4 kg of fully frozen water-packs per 50 litres of gross freezer volume must remain fully frozen at the end of the 12-hour night phase whilst maintaining the temperature control specified in clause 4.2.7. No standard set for power consumption but report the energy consumption in kWh/day, the percentage on-time during the 12-hour solar phase and graphically display on/off cycles.

**Acceptance criteria** (water-pack storage compartment capacity): Stabilized internal temperatures maintained between  $-5^{\circ}\text{C}$  or colder and  $-15^{\circ}\text{C}$  to  $-25^{\circ}\text{C}$  in the vaccine storage compartment. For freezers of less than 50 litres of gross freezer volume a minimum of 3.4 kg of fully frozen water-packs must remain fully frozen at the end of Step 10 whilst maintaining the temperature control specified in clause 4.2.7. For freezers with at least 50 litres of gross freezer volume a minimum of 4.8 kg of fully frozen water-packs per 50 litres of gross freezer volume must remain fully frozen at the end of Step 10 whilst maintaining the temperature control specified in clause 4.2.7. No standard set for power consumption but report the energy consumption in kWh/day, the percentage on-time during the 12 hour solar phase and graphically display on/off cycles.

**Rejection criterion:** Failure to meet one or more of the acceptance criteria.

### 5.3.6 *Test 5: Day/night and power consumption*

**Application:** Day/night and power consumption apply to all appliances. Frozen [water-pack](#) storage instructions (Steps 1,2,4,5,6 and 7) apply only to combined appliances.

**Power:** Simulated solar power as clause 5.3.2.

- **Step 1:** Incorporating the result from Test 4, allow the appliance to stabilize for a further 24 hours only with the [water-pack](#) freezing compartment filled equivalent to the final [water-pack storage compartment capacity](#) result from

Test 4.

- **Step 2:** For further loading (see Step 6), label and stabilize additional [water-packs](#) at +43°C.
- **Step 3:** Beginning with a 12-hour day phase of a 24-hour solar cycle hold the temperature of the test chamber to +43°C, for a further 12 hours. Then lower the temperature to +25°C over a three-hour period. Hold at +25°C for a further nine hours. Next raise the ambient temperature to +43°C over a further three-hour period. Hold at +43°C for a further 9 hours. Repeat this simulated day-night cycle for five complete 24-hour solar cycles in total.
- **Step 4:** At the end of the first 12-hour night-time phase of a 24-hour solar cycle remove a minimum of 1.6 kg of packs and not less than 2.4 kg per 50 litres of gross freezer volume of packs from the freezer compartment. These packs shall not be returned to the freezer at this time.
- **Step 5:** Record compartment temperatures every minute for the whole test. Measure electricity consumption and the cooling system duty cycle over the same test duration and report energy consumption in kWh/day, the percentage on-time over the 12-hour solar phase and graphically display on/off cycles.
- **Step 6:** At the end of the 12-hour solar day phase load [water-packs](#) which have been stabilized in accordance with Step 2. This loading replaces the packs removed in Step 4<sup>4</sup>.
- **Step 7:** At the end of the next night phase, record each pack volume, location and condition (i.e. fully frozen or not fully frozen) per instructions in **Annex 1**- Fully frozen water-pack determination. Except for packs which are to be removed in Step 4, return packs to exact positions without delays.
- **Step 8:** Repeat steps 3 to 7 until five complete day-night cycles have been completed. If possible, packs removed in each repetition of Step 4 must include packs by rotation not previously removed. Record and report the maximum number and volume of fully frozen packs that can remain fully frozen at the end of every nighttime phase.
- **Step 9:** Review the data and calculate the MKT for each sensor in the [vaccine storage compartment](#) over the five-day period. Record the highest and lowest temperatures reached during the test.

**Acceptance criterion:** [Vaccine storage compartment](#) temperatures must remain within the [acceptable temperature range](#) throughout the test. The MKT of the worst-case sensor must not be outside the range -15°C to -25°C. No standard set for the number of fully frozen and non-fully frozen packs at the end of each night-time phase but results to be reported as the quantity and volume of stored frozen [water-packs](#) that can remain fully frozen at the end of testing over a five-day period. No standard set for power consumption but report the energy consumption in kWh/day, the percentage on-time during the 12-hour solar phase and graphically display on/off cycles.

**Rejection criterion:** Failure to meet one or more of the acceptance criteria.

---

<sup>4</sup> Note: It must be possible to remove frozen water-packs without any undue force or delay.

### 5.3.7 Test 6: Autonomy time (water pack compartment, combined appliances only)

**Application:** Combined appliances only.

**Power:** Simulated solar power as clause 5.3.2.

- **Step 1:** Set the test chamber ambient temperature to +43°C. Continue the Test 5 conditions with the water-pack freezing compartment loaded to the measured water-pack storage capacity and the vaccine storage compartment stabilized between -15°C and -25°C.
- **Step 2:** Connect appliance to a reduced output power supply at the time when the compressor or cooling circuit is turned off at the end of the 12-hour solar cycle. The reduced output power supply must provide the same voltage and daily runtime as specified by the manufacturer, but no more than 5% of the solar array ampere (Imp) input specified by the manufacturer based on the [solar radiation reference period](#). Measure electricity consumption and the cooling system duty cycle over the same test duration and report energy consumption in kWh/day, the percentage on-time over the 12-hour solar phase and graphically display on/off cycles.
- **Step 3:** At the end of each 12-hour night phase remove water-packs one at a time and determine which are fully frozen and which are not fully frozen per instructions in **Annex 1** - Frozen Water-pack Determination. Record each water-pack volume, location and condition (i.e. fully frozen or not fully frozen) and without delay place them back in the freezing compartment. At the end of each night phase visually inspect the level of fully frozen packs and record.
- **Step 4:** Discontinue water pack freezer autonomy testing when the vaccine compartment breaches -15°C or when the load of fully frozen water-packs falls below the minimum daily water-pack freezing requirement (i.e. either a minimum of 1.6 kg of water-packs and not less than 2.4 kg per 50 litres of gross freezer volume of frozen water-packs remaining). Round down to nearest half day increment to report the freezer autonomy period in increments of half days.

**Acceptance criterion:** Water pack freezer autonomy result is a minimum 72 hours at the [solar radiation reference period](#) and when tested for the [hot zone](#).

**Rejection criterion:** Failure to meet the minimum [autonomy](#) during [hot zone](#) testing.

### 5.3.8 Test 7: Door opening

**Application:** All appliances.

**Power supply:** As per manufacturer's specification used in Test 2.

**Ambient temperature:** +43°C continuous.

Record temperatures every minute and record power consumption.

- **Step 1:** Ensure all internal temperature sensors are stabilized at [freezer](#)

- **temperature** and within the **acceptable temperature range**.
- **Step 2:** Open all compartment lids/doors of the appliance. This must include primary as well as secondary lids/doors, since some appliances have secondary lids/doors. Allow the compartment lid or door to stay fully open at least 90° for one minute.
- **Step 3:** After one minute, close the lid/door and continue to monitor temperatures of the vaccine compartment for at least two hours as the appliance cools and internal temperatures stabilize.

**Acceptance criteria:**

- Vaccine compartments must not become warmer than 10 degrees above **freezer temperature** for longer than one hour.
- Vaccine compartments must not become warmer than 20 degrees above **freezer temperature** or +5°C for any amount of time.
- Following any excursion warmer than the coldest target internal **freezer temperature**, the appliance must return to the **freezer temperature** and within the acceptable temperature range within 30 minutes.

**Rejection criteria:** Failure to maintain temperatures within the above criteria.

#### 5.4 Test criteria for qualification

A final report to be issued after all testing is complete. Each test must have a full analysis of all logged temperatures (including ambient temperatures) which summarizes the maximum, minimum and mean temperatures for each sensor and for different sections of a test, e.g. for the holdover test, day-night test and door-opening test.

Power consumption, if applicable to the test, should also be analyzed. This includes the kWh/day and instantaneous power at any point in the test.

Temperature results to be presented graphically so that all instantaneous peaks and troughs can be clearly seen with t = 0 hours at the start of each test. Power consumption and/or compressor on-off cycling should be displayed with each temperature graph.

The report should also contain the following and non-compliances must be indicated:

- **Summary:** Conclusions, comments and recommendations, including confirmation of the temperature zone(s) for which the product is suitable.
- **Test 1:** Comments on samples received, tabulated data on the type examination test and relevant photographs.
- **Test 2:** Results of cool-down and stable running test.
- **Test 3:** Results of autonomy test (vaccine compartment).
- **Test 4:** Results of water pack freeing and capacity test.
- **Test 5:** Results of day night test.
- **Test 6:** Results of autonomy test (water pack compartment if a combined appliance).
- **Test 7:** Results of door opening test.



- **Annexes:** The following should be included:
  - Description of the test instrumentation.
  - Diagrams showing the location and identification codes for temperature sensors, clearly distinguishing between sensors measuring vaccine, water-pack, freezer and evaporator temperatures.
  - Additional supporting documentation requested and received from the [legal manufacturer](#) or [reseller](#) during the course of the type-testing.

Individual minute-by-minute logged test results (raw data) of temperature and energy or power data and instrumentation calibration certificates shall be held on file for later examination.

## 6. Quality control checklist

### 5.5 Quality control standards

All testing and reporting must be carried out in accordance with the requirements of **ISO 17025:2017** or later edition.

### 5.6 On-site inspection

An on-site inspection of the manufacturing plant may be required.

## 7. Prequalification evaluation

A product will qualify for inclusion on the register of PQS prequalified vaccine and vaccine and water-pack freezer equipment in accordance with WHO procedures provided the final report indicates full conformity with the requirements of PQS product specification **WHO/PQS/E003/FZ04**.

## 8. Modified products

The [legal manufacturer](#) or [reseller](#) must notify WHO [in writing](#) of any changes which affect the performance of the product. WHO will carry out a desk evaluation of the reported change(s). If any change is deemed adversely to affect the performance of the product, WHO may request full or partial re-verification based on the test procedures described in this document.



## Annex 1 – General test conditions

- Appliance to be set up in accordance with **IEC 62552-1** Figure A.2.
- Test sample to remain in the test ambient for a sufficient time to achieve a condition where the whole appliance is at maximum climate zone ambient of M:+27°C or T:+32°C or H: +43°C for at least 48 hours before testing commences.
- Carry out tests in a test chamber in which temperatures can be controlled to 1°C and humidity within the range of 65% to 75% unless otherwise stated below. Humidity for each test must be stated in the report.
- The test ambient should be measured at each side of the appliance in accordance with **IEC 62552-1** Figure A.2 & clause A.4.5 except where there is a side vent (e.g. a chest-type appliance), where the ambient on that side should be measured at a similar distance in front of the appliance.
- All test chamber logged ambient temperatures must be within  $\pm 1^\circ\text{C}$  with the mean of the logged ambient within  $\pm 0.5^\circ\text{C}$ .
- Maximum test chamber temperatures of M:+27°C or T:+32°C or H: +43°C are required for the tests depending on the declared climate zone for the appliance.
- The speed of the air in the test chamber must be 0.5 m/s or lower.
- All temperatures must be continuously monitored to an uncertainty no worse than  $\pm 0.5^\circ\text{C}$  from the tip of the sensor to displayed readings or captured data. The influence of any instrumentation or temperature sensor set-up on appliance performance must be extremely small. e.g. gaps in the door seal cause by temperature sensor wires must be sealed.
- Up to 24 simultaneous temperature measurements may be required for a single appliance. The suggested temperature sensor specification and locations are shown in **Annex 2**.
- Position the test appliance in the test chamber with its back face no more than 50 mm clear of one of the chamber walls. This clearance may be less than 50 mm where appropriate spacers are provided. This clearance must not be larger than 50 mm even if larger spacers are provided.
- Ensure that the appliance is accurately levelled.

### Stabilization times

Internal conditions in the vaccine storage compartment can be said to be stable when:

- The temperatures in the vaccine storage compartment are at or colder than the target internal temperature and the thermostat has been cycling for 24 hours, or the temperature at each of corresponding points during successive operating cycles varies by less than  $\pm 0.5^\circ\text{C}$  and there is no marked trend away from the mean temperature at that point over 24 hours.
- The cooling system, if cycling, has exhibited consistent on/off operation for at least 24 hours.

### Vaccine storage capacity measurement

Measure the **gross volume** of the appliance in accordance with **IEC 62552-3** Annex H by measuring orthogonal dimensions of approximate cuboid spaces and calculating the total volume.

Multiply the **gross volume** by 0.67 to obtain the **vaccine storage capacity**<sup>5</sup>. State both the **gross volume** and the **vaccine storage capacity**. **Gross volume** measurements should be kept on file for later examination.

#### Dual compressor or multiple cooling circuit appliances

All cooling systems should be switched on during all tests.

#### Fully frozen water-pack determination:

The following tests are used to determine whether a **water-pack** is fully frozen, partially frozen, or unfrozen. While the assessment is not 100% accurate, misclassifications are usually conservative in nature: **water-packs** that are fully frozen are sometimes classified as partially frozen rather than partially frozen **water-packs** being classified as fully frozen. A fully frozen **water-pack** contains only ice. A partially frozen **water-pack** contains both ice and water. An unfrozen **water-pack** contains only water

Perform the all of the following tests on a **water-pack**:

- Shake test - Shake the **water-pack** while holding the **water-pack** near the assessor's ear. If the sound of water sloshing in the **water-pack** is heard, then the **water-pack** fails the shake test.
- Tilt test – Tilt the **water-pack** back and forth while looking for the movement of air or water in the **water-pack**. If the movement of air or water is observed, then the **water-pack** fails the tilt test.
- Bulge test – Water expands when it freezes. Examine the **water-pack** for localized bulging near the centerline of the **water-pack** when viewing the **water-pack** from the side. If localized bulging is not present, then the **water-pack** fails the bulge test.
- Classify the **water-pack** as follows:
  - If the **water-pack** passes all three tests, then the **water-pack** is fully frozen.
  - If the **water-pack** fails one or more tests, then the **water-pack** is partially frozen or unfrozen and fails the test

---

<sup>5</sup> In accordance with the method as described in the Vaccine Management Handbook Section 3.3.2.

## Annex 2 – Temperature sensor specification and locations



- Sensors are to comply with **IEC 62552**, Clause A.2.6 with sensor a total uncertainty<sup>6</sup> of  $\pm 0.5^{\circ}\text{C}$ , inserted into brass or tin-covered copper mass of  $25\text{ g} \pm 5\%$  and of minimum external area (diameter = height = about 15.2 mm).
- Sensor positions are indicated by **Annex 2** Figure 1 below. Place sensors at the center of the vaccine load compartment and at other positions which are likely to experience extremes of temperature within the vaccine storage compartment. Such positions might be near door seals, or where air circulation is restricted by the appliance design.
- Except for the centrally placed sensors, they should be within 25 mm of the walls and corners of the space where vaccine is to be stored so that the sensors experience the same temperature of any stored vaccine.
- Where vaccine storage bins or baskets are supplied with the appliance, except for centrally placed sensors, fix sensors within 25 mm of the volume(s) defined by the internal faces of these basket(s).
- Fix the sensors in position so that they cannot be displaced during the course of the tests. Sensors may be fixed in position using thin rigid wire, tape or similar materials which do not affect the thermal performance of the appliance nor affect the sensor reading.
- After initial setup, do not alter the position of sensors during subsequent tests.
- Monitor all sensors so that an overall picture of the temperature distribution can be obtained.

---

<sup>6</sup> Total uncertainty being from the tip of the sensor to the readout or data-recording.

**Figure 1: Sensor placement examples** (note: REFRIGERATOR label to also include freezers)

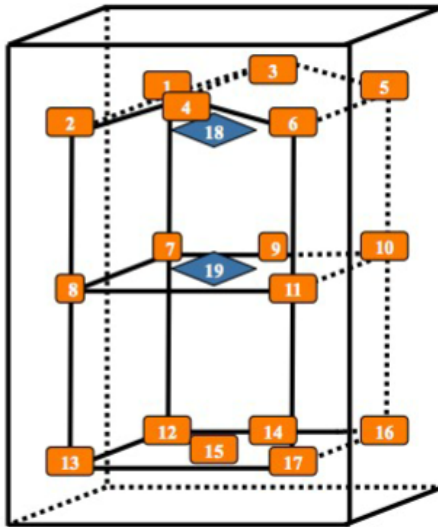
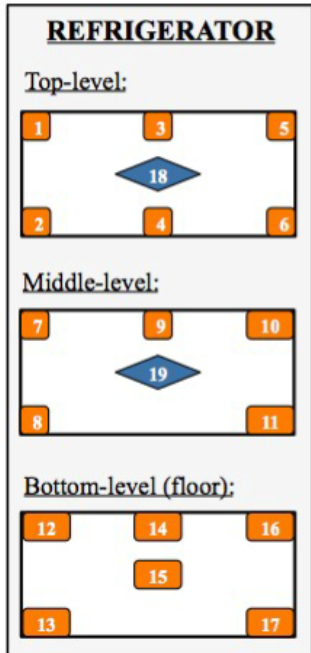

**UPRIGHT COMPARTMENT**

-  Surface sensors
-  Ambient sensors



All sensors are to be positioned according to this layout and in direct contact with compartment surfaces.

**CHEST COMPARTMENT – NO STEP**

-  Surface sensors
-  Ambient sensors

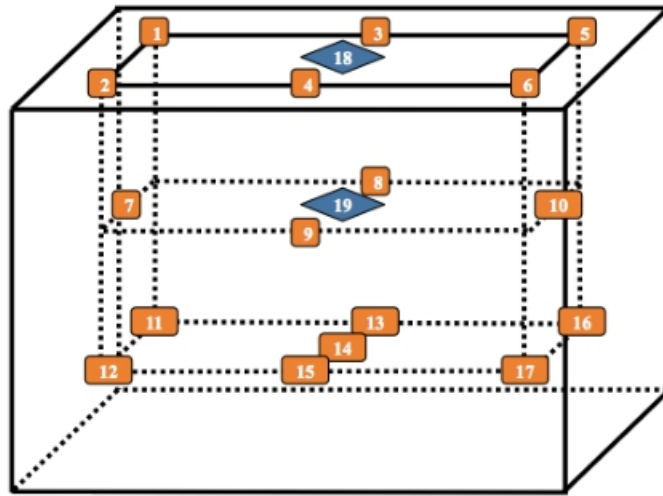
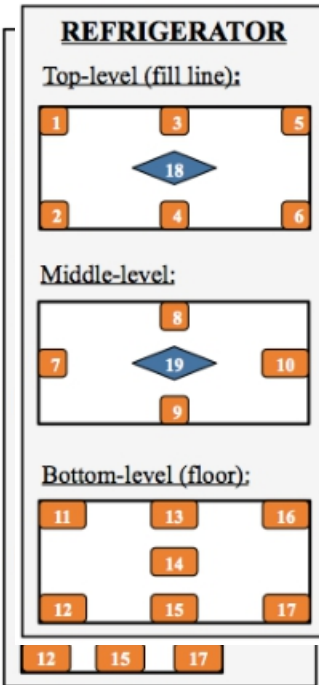

All sensors are to be positioned according to this layout and in direct contact with compartment surfaces.

# CYLINDRICAL CHEST COMPARTMENT

- 13 Wall sensors
- 2 Ambient sensors

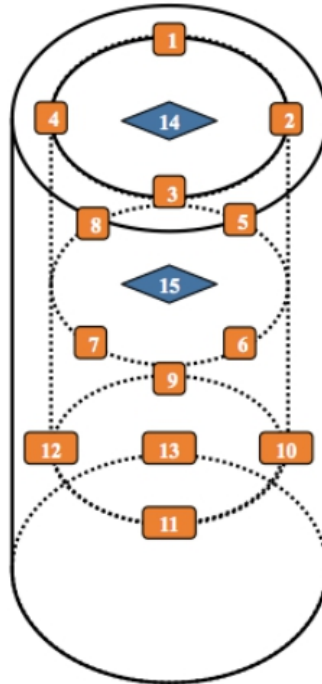
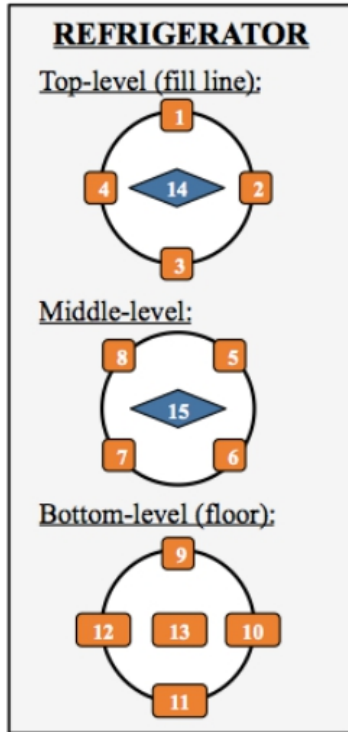

**Revision history**

<b>Date</b>	<b>Change summary</b>	<b>Reason for change</b>	<b>Approved</b>